

High peak power Ytterbium doped fiber amplifiers

W. Torruellas^a, Y. Chen^a, B. McIntosh^a, J. Farroni^b, K. Tankala^b, S. Webster^c, D. Hagan^c, M.J. Soileau^c, M. Messerly^d, J. Dawson^d

- a) Fibertek Inc., 510 Herndon Parkway, Herndon, VA 20170
- b) Nufern, 7 Airport Park Road, East Granby, CT 06026
- c) CREOL/UCF, P.O. Box 162700, Orlando, FL 32816
- d) LLNL, NIF, L-470 7000 East Avenue, Livermore, CA 94550

1 Abstract

We have tested a series of Ytterbium doped large core fibers operating near 10Kpps and producing pulses of approximately 1ns. We have achieved 850 μ J/pulse resulting in peak powers in excess of 2MW with 0.4ns pulses and near diffraction limited beams. In another fiber, we have achieved over 1.5mJ/pulse with pulses of 900ps corresponding to 1.65MW of peak power and M^2 of 2.5. In the latter case, wall-plug efficiencies, excluding cooling of the pump diode lasers, in excess of 15% were also achieved. This fiber amplifier has operated for 2 months without any degradation or observed optical damage.

2 Introduction

Fibertek has been developing laser sources capable of achieving >100W at 1064nm with very good beam quality $M^2 < 2$ delivering pulses of less than 1 nanosecond. While diode pumped solid state lasers can potentially achieve this performance they suffer from degraded electrical-to-optical efficiency. Indeed, in order to achieve good optical beam quality, optical to optical efficiency is typically degraded in order to control thermally induced optical aberrations.

On the other hand, Ytterbium doped optical fibers have shown remarkable optical efficiencies, CW powers in excess of 1kW while maintaining good optical beam quality. However, significant challenges remain in the power scaling of short pulse (~ns duration), lower repetition-rate fiber laser systems. In this regime, the value of the laser system comes from the higher peak power and significant pulse energy but management of phenomena such as Amplified Spontaneous Emission (ASE), Stimulated Raman Scattering (SRS) Self-Focusing (SF) and primarily optically induced damage become paramount.

To date Fibertek has achieved peak powers in excess of 2MW with engineered double-cladding Ytterbium doped silica fibers and stable operation over several Months. We believe this represents the highest peak power reported in such fibers with sub-1ns pulses. While we are operating below the critical self-focusing limit in bulk¹, $P_{cr} \sim 4.5$ MW, interestingly, the energy fluence is comparable to some reported value for single pulse optical damage in pure fused silica^{2,3}, 50J/cm². We believe this article clarifies that operating near this limit is possible for silica based fiber amplifiers.

3 Optical Damage

In this study we first compare Laser Induced Damage Thresholds (LIDTs) of different Ytterbium doped core concentrations used in high peak power fiber amplifiers. Bulk LIDTs are determined in fiber preforms composed of two types of fused silica jackets and Ytterbium/Germanium doped cores/claddings respectively. For a detail description of the methodology we used to determine the LIDT on this samples we refer the reader to a parallel SPIE proceeding.⁴ Here, we report only the most relevant results and deduce implications to the fiber design and the high peak power operation of such fibers. In section 5 we report the results of our tests on a series of Ytterbium doped double cladding fiber amplifiers where the effective modal area was progressively increased.

Figure 1 shows the single and 1000 shot mean values of the LIDT for various Ytterbium doped preforms. For the single shot data, the Ytterbium doped preforms show a slightly decreasing LIDT with increasing Yb doping. As expected, the outer fused silica shows a higher LIDT than the doped cores. Results for the 1000 shot data are relatively close to the single shot data and may have slightly increased due to laser conditioning. As is known with such damage

measurements, LIDTs can significantly vary. The important observations are that there appears to be little or no laser-induced fatigue at this focusing geometry and the core damage thresholds are not significantly influenced by the presence of Yb dopants as might be expected due to the very small absorption of Yb at 1064nm. This is important because our measurements at 1064 nm are within the emission spectra of Yb doped fibers (1030nm – 1110nm). The error bars have been calculated from the standard error of the mean. The experimental error for these measurements is approximately $\pm 20\%$ and is graphed as the solid lines in Figure 1. The minimum and maximum LIDT values are also displayed by triangles pointing up and down respectively. Shown in Figure 2 are the single shot probabilities of damage of the Yb doped cores and two types of fused silica. As previously mentioned, the number of data points in the cores is limited, and the statistical significance of the Gaussian distribution fits has some additional error due to the small sample size.

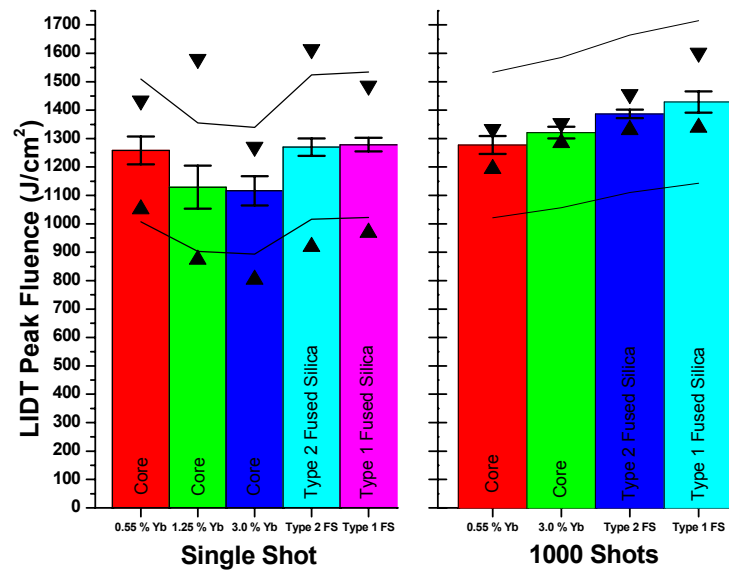

Figure 1: Single and 1000 shot summarized LIDT results of the Yb doped cores and the two types of fused silica. Minimum and maximum LIDT are displayed by triangles pointing up and down respectively. The $\pm 20\%$ experimental error is shown by the solid black lines.

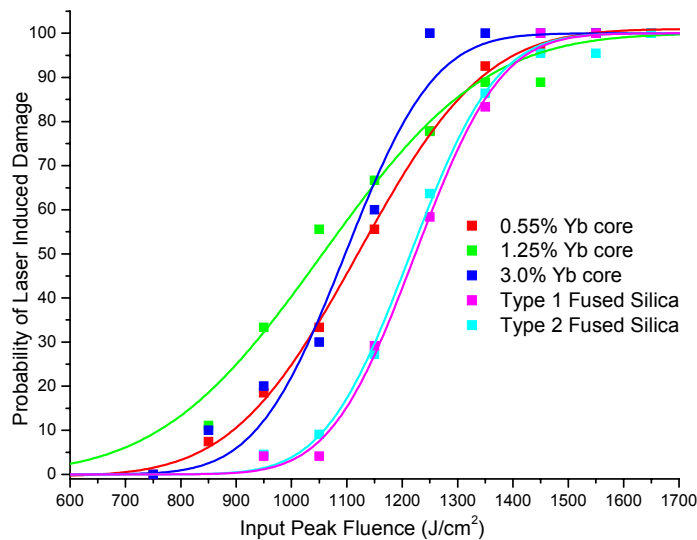

Figure 2: Single Shot probability of laser induced damage of the Yb doped cores and the two types of fused silica.

The results shown in the previous figure were achieved with pulses of 6ns in duration. In summary, single and 1000 shot (N-on-1) LIDT measurements were performed in the same Ytterbium doped preforms used to make high peak power fiber amplifiers. Single and 1000 shot data suggest slight laser conditioning of the preforms and rule out laser fatigue in the doped cores and surrounding fused silica. At 1064nm, inside the emission spectra of ytterbium, there

seemed to be little influence of the Ytterbium concentration on the measured LIDT. In the case of Nufern Fiber a bulk Optical damage for 6-7ns pulse of 900J/cm² results from our measurements. This value would be scaled down to approximately 300J/cm² for 1ns pulses and represents the maximum optical fluence this glass samples can be exposed to.

The following figure shows the surface optical damage measurement on a silica window for 6-7ns pulses. This value is at least 4 times smaller than the bulk LIDT measurements and would scale down for 1ns pulses as the square root of the pulse duration. As a result we believe the reported value of 40-50J/cm² corresponds to the surface damage threshold. We need to take this value into account at the interface of the fiber with air.

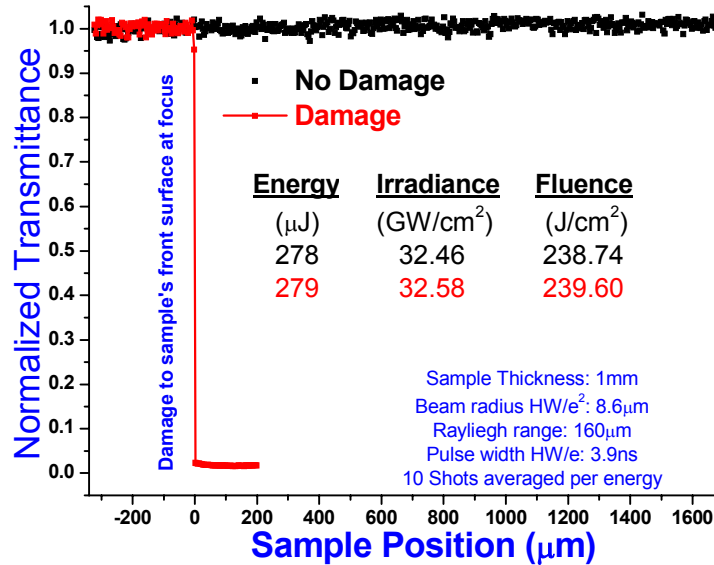

Figure 3: Surface damage measurement on a polished fused silica window.

4 Consequences to optical Fiber design

In order to limit the propagation in optical fibers to just a few modes the core diameter needs to be less than 50μm, resulting in a maximum effective area of less than 2000μm². Therefore from this consideration we expect the maximum energy we can propagate in a fiber is approximately 6mJ for 1ns pulses, namely 300J/cm². A more robust operation would only allow less than 3mJ/pulse.

At the fiber/air interface a bulk silica rod is typically spliced. This element sometime called “fiber endcap”, allows the beam to diverge to approximately 1/3 of the glass cladding diameter to prevent diffraction effects. In our case, a 250 μm cladding results in a modal area at the silica/air interface of approximately 5000μm². With a surface damage of 50J/cm², for 1ns pulses, the corresponding maximum pulse energy is 2.5mJ/pulse. A good safety margin limits our design to an operation at less than 1.5mJ/pulse and thus an average power of 15W at 10Kpps.

We need to make sure that this fluence is below the critical self focusing power in the bulk silica endcap rod. Since the early days of Laser science, it has been known that high peak power lasers can induce lensing in optical media. This lensing can result in catastrophic damage above a critical power. This power is given by the following equation:

$$P_{crit} = \frac{0.15\lambda^2}{n_0 n_2}$$

Note that the critical power is independent of the area of the beam. It only depends on the wavelength of the laser, the linear refractive index n_0 and the nonlinear intensity dependent refractive index n_2 . In the case of fused silica, $n_0=1.45$, $n_2=2.5 \times 10^{-20}$ m²/W, resulting in a critical self-focusing power of 4.5MW. We will be operating at approximately a peak power per pulse of 1.5MW and therefore away from the critical self-focusing peak power regime.

It is thus critical to achieve the maximum practical modal effective area in a fiber to achieve the above performance of 1.5mJ/pulse for 1ns pulses. Section 7 describes our attempt to increase the effective modal area in Ytterbium doped fibers to 2000μm². The next section provides the testing results of commercially available fibers including the fibers fabricated for this effort.

5 Test results on Ytterbium doped Fiber Amplifiers

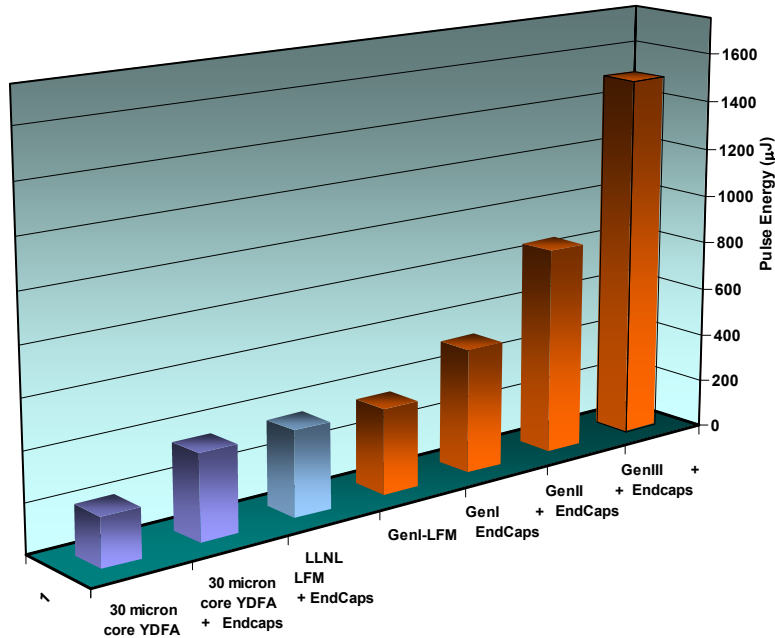

Figure 4: Pulse energies achieved for a series of Ytterbium doped double cladding fibers.

The above figure shows the best results to date for a series of Ytterbium doped double cladding optical fibers. We used a commercially available polarization maintaining fiber with a 30 micron core and 250 micron first silica cladding as our reference fiber. This fiber has been operated in our laboratories for over 2 years producing over 200 µJ/pulse with pulses of approximately 1ns. Our effort has allowed an almost 10 fold increase in pulse energy produced by such fibers. To date we have been able to operate at 1.5mJ/pulse for over 2 months. These results give us confidence that Ytterbium doped double cladding fiber technology is capable of field operation in military and space environments where sub 1ns pulses are required and 1mJ level pulse energies are needed for detection and ranging applications.

6 Experimental Setup

Our experiment expands on the NRL work⁵, where peak powers of 300KW had been demonstrated in double cladding pumped Yb doped fibers. A first stage fiber amplifier is seeded with a commercial micro-laser producing sub 1ns pulses at 12Kpps. The first stage consists of large core double cladding fiber pumped by a single fiber pigtailed laser diode bar operating at 976nm. This amplifier has produced over 2.6W of average power. The output of the first amplifier then seeds a high power amplifier producing over 18W of average power. Both amplifiers are setup in a counter-propagating pump configuration. The following figure depicts our experimental setup. A wall-plug efficiency, excluding cooling of the laser diode bars, in excess of 15% is achievable.

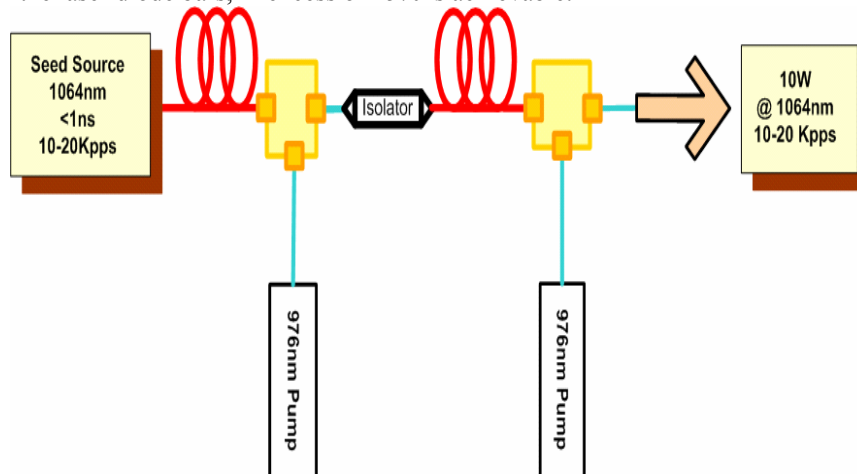

Figure 5: Experimental Setup of the high peak power demonstration in a Large-Flat-Mode fiber power amplifier.

7 Fiber design

In order to prevent optical damage we decided to increase the modal area in the fiber. Recent reports^{6,7} from LLNL indicate that small modifications of the core refractive index can increase the modal effective area by factors of 2-4, with a small penalty in beam quality. In collaboration with Nufern we have gone through three iterations of this fiber design. The maximum peak power we have achieved is in excess of 2MW.

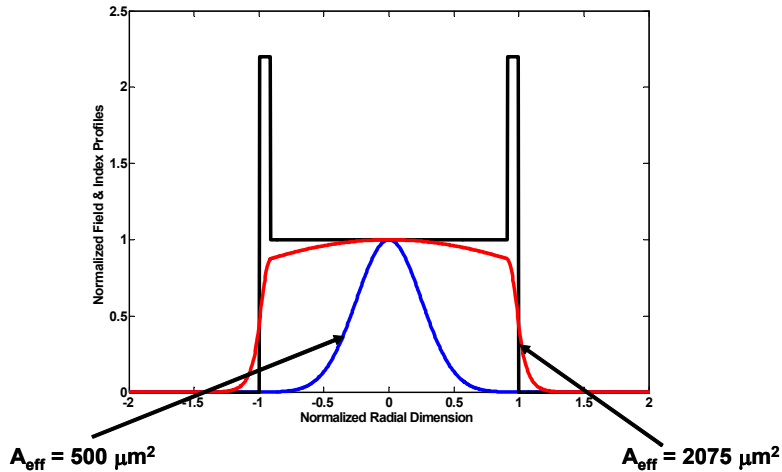

Figure 6: Mode profiles of the step index and Large-Flat-Mode fiber.

8 Experimental results for the Large Flat Mode Fibers

To date the following represents our best results.

Parameter	Achieved
Average Power	>18W
Pulse Energy	1.5mJ @ 15W
Repetition Rate	10Kpps @ 15W
Pulse Duration	<0.5ns @ 10W & 0.9ns@15W
M^2	<1.15 @ 10W & <2.5 @15W
Spectral Linewidth	<25GHz @ 15W
SNR Ratio in 0.1nm	-27dB @15W
Wall-Plug Efficiency	15% @ 15W

In order to suppress the advent of Stimulated-Raman-Scattering we have optimized the fiber length and the core refractive index profile. The following figure shows the output power from the second stage amplifier measured with a calibrated Powermeter. Limited ASE and SRS were observed in this case. The output pulses were measured to be approximately 900ps (FWHM) in duration. The peak power is therefore in excess of 1.75MW. Similar experiments with another fiber refractive index profile achieved 850μJ/pulse with a pulse duration of less than 400ps, this result indicates a peak power in excess of 2MW. Finally an M^2 measurement showed an excellent beam quality, $M^2 < 1.15$, in the latter case.

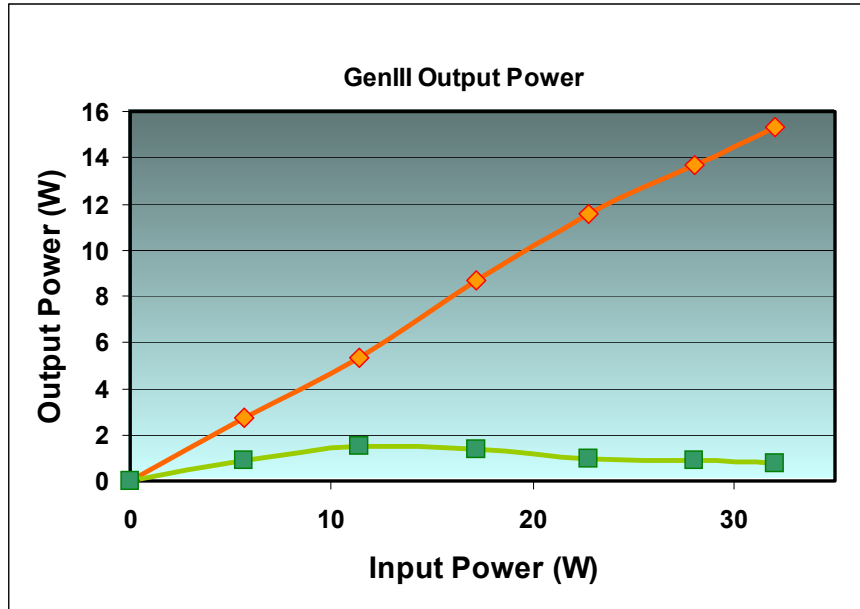

Figure 7: Output power of the GenIII LFM fiber versus input pump power (top curve). The pump leakage is also shown (bottom curve)

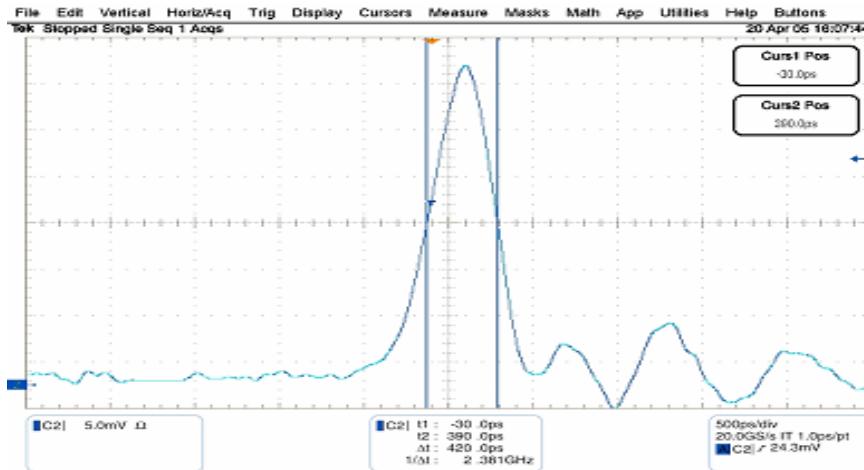

Figure 8: Output pulse measured with a 2.5GHz oscilloscope with a 120ps rise time and a Newport AD300 amplified InGaAs detector. The GenII LFM was producing 10W of average power and a peak power in excess of 2MW.

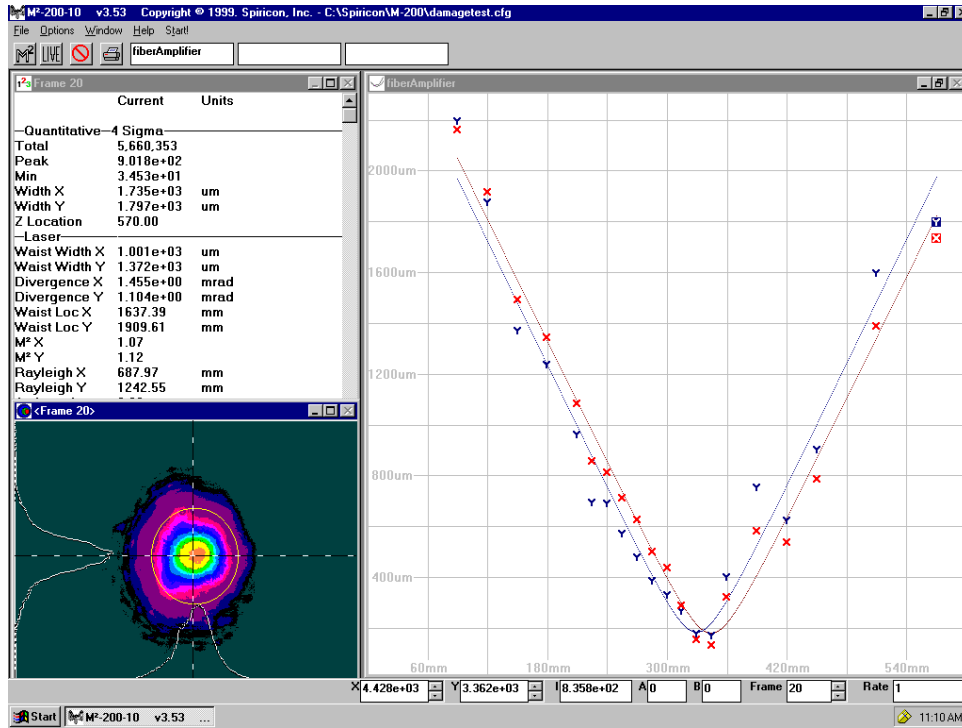

Figure 9: $M^2 < 1.15$ measurement at 10W of average power.

9 Conclusion

Refractive index engineering of Ytterbium doped fibers allows for increased effective fiber modal areas and thus allows for operation at unprecedented peak power levels in such fibers. The output peak power level is limited by optical damage, saturation of the power in band by Stimulated Raman Scattering and eventually self-focusing in the endcaps.

10 Acknowledgements

We would like to acknowledge the support of the Air Force Research Laboratory under contract FA9451-04-D-0413.

11 References

- [1] R. Wood, "Laser Damage in Optical Materials", Adam Hilger, Bristol (1986).
- [2] M. D. Perry, B. C. Stuart, P. S. Banks, M. D. Feit, V. Yanovsky, A. M. Rubenschick, "Ultrashort-pulse laser machining of dielectric materials", Jour. Appl. Physics, 85, 6803-6810 (1999).
- [3] L. Gallais, J. Y. Natoli, C. Amra, "Statistical study of single and multiple pulse laser-induced damage in glasses", Opt. Exp., 10, 1465-1474 (2002).
- [4] S. Webster, F.C. McDonald, A. Villanger, M.J. Soileau, E.W. Van Stryland, D.J. Hagan, B. McIntosh and W. Torruellas, J. Farroni and K. Tankala, "Optical Damage Measurements for High Peak Power Ytterbium Doped Fiber Amplifiers", SPIE Proceedings of the 2005 Optical Damage Symposium, Boulder, CO Sept. 2006.
- [5] F. D. Teodoro, J. P. Koplow, S. W. Moore, D. A. V. Kliner, "Diffraction-limited, 300-kW peak-power pulses from a coiled multimode fiber amplifier", Opt. Lett., 27, 518-520 (2002).
- [6] J. W. Dawson, R. Beach, I. Jovanovic, B. Wattellier, Z. Liao, S. Payne, C. P. J. Party, "Large Flattened mode optical fiber for reduction of nonlinear effects in optical fiber lasers", SPIE proceedings, Vol. 5335, 132-139 (2004).
- [7] A. K. Ghatak, I. C. Goyal, R. Jindal, "Design of Waveguide Refractive Index Profile to Obtain Flat Modal Field", SPIE proceedings, Vol. 3666, 40-44 (1998).