

PLC-900 Fiber Polarization Controller

- Thorlabs' PLC-900 in-line polarization controller manipulates the output polarization state for $\varnothing 900 \mu\text{m}$ tight-buffered fiber. This manipulation does not produce intrinsic loss nor back reflections.
- The PLC-900 uses mechanical compression and rotation of the fiber to produce stress-induced birefringence, which in turn produces changes in the output polarization.
- The stress-induced birefringence can be adjusted continuously, allowing any arbitrary input polarization state to be converted to any desired output polarization state.

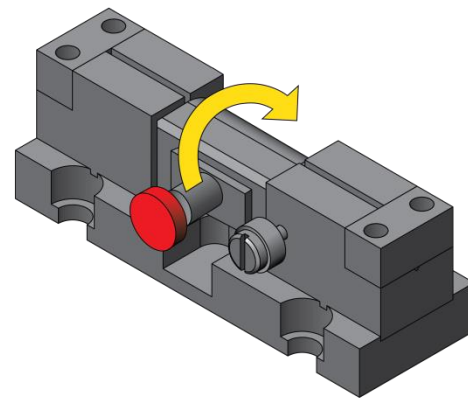
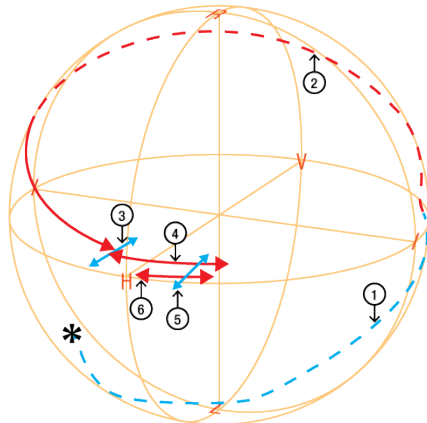

Presentation content is available to customers upon request. Please contact us if you would like to publish any of the information contained within this presentation.

Background

- The PCS-900 In-line Fiber Polarization Controller creates mechanical stress-induced birefringence on a single mode $\varnothing 900 \mu\text{m}$ tight-buffer fiber, thereby changing the input polarization to any desired polarization state.
- Stress-induced birefringence is created through two mechanisms: compressing and twisting of the fiber.

Compressing a fiber of diameter d with force F results in an approximate retardation given by

$$\delta \sim 6 \times 10^{-11} \frac{F}{\lambda d}$$

for wavelength λ within a silica fiber.¹

- Here we demonstrate that a subsequent combination of these two mechanisms and their repeated iterations can be used to create unique polarization states, thereby demonstrating that the PLC-900 fiber polarization controller can be used to create a myriad of polarization states.

[1] A.M. Smith, "Single-mode fibre pressure sensitivity," Electron Lett. **16**, 773-774 (1980).

[2] R. Ulrich, A. Simon, "Polarization optics of twisted single-mode fibers" Appl. Opt. **18**, 2241-2251 (1979).

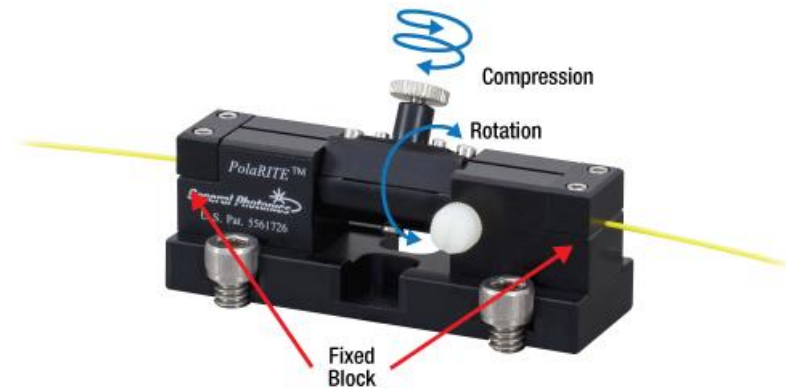

Twisting regions of fiber by rotating a paddle by angle τ rotates the polarization by an angle

$$\theta = \alpha \tau$$

where $\alpha = -n^2 p_{44}$ is based on the elasto-optical coefficients p_{44} of the fiber and refractive index n of the core.²

Experimental Design

- The light from a 1310 nm fiber-coupled laser source (S1FC1310) was coupled into an FC/PC-connectorized, $\varnothing 900 \mu\text{m}$ tight-buffer jacket, single mode fiber (CCC1310-J9). This fiber was secured within the PLC-900 polarization controller.
- After the PLC-900, the fiber was coupled into a fiber collimator (F220FC-C). The free space beam was either directed through an analyzer assembly, consisting of a linear polarizer (LPNIR-100), quarter-wave plate (WPQ05M-1310), and power sensor (S132C) (wave plate only used for circular polarization), or incident upon a polarimeter (PAX5710IR2-T).
- The polarization change induced by the PLC-900 was measured with the analyzer assembly and confirmed with the polarimeter.

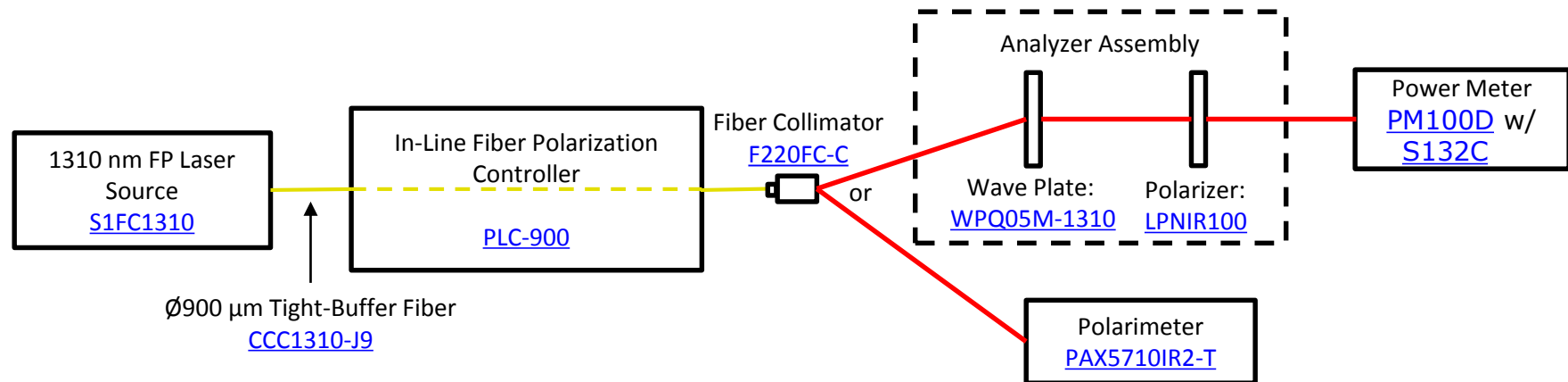

Experimental Setup

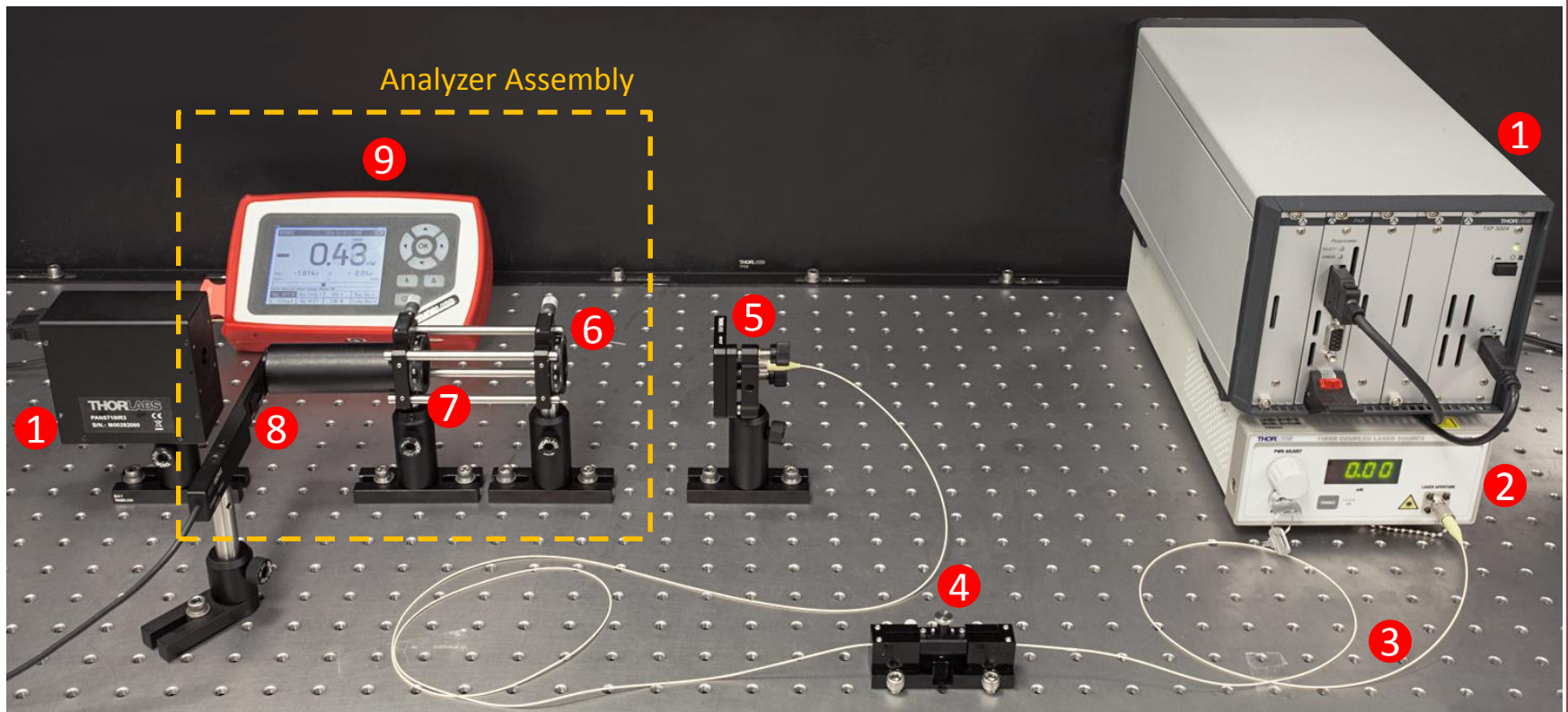

- 1) 1000 – 1250 nm Polarimeter: [PAX5710IR2-T](#)
- 2) 1310 nm Benchtop Laser Source: [S1FC1310](#)
- 3) 1260 – 1625 nm, \varnothing 900 μ m Jacket SM Fiber: [CCC1310-J9](#)
- 4) In-Line Fiber Polarization Controller: [PLC-900](#)
- 5) Fiber Collimator: [F220FC-C](#)

- 6) 1310 nm Quarter-Wave Plate: [WPQ05M-1310](#)
- 7) 650 – 2000 nm Linear Polarizer: [LPNIR100](#)
- 8) 700 – 1800 nm Photodiode Power Sensor: [S132C](#)
- 9) Power and Energy Meter Console: [PM100D](#)

Results: Affect of Compression Force

- Compression force on the fiber was visualized by manually rotating the knob from minimum (0%) to maximum (100%) compression with rotator assembly locked down at -90, -45, 0, 45, +90 degrees.
- Applying compression force on the fiber rotated the output polarization state about a circle on the Poincaré sphere, similar to rotating a quarter-wave plate.
- This path, plotted along the Poincaré sphere, stayed relatively consistent for various angular positions of the rotator assembly; the center of the path translated between the linear polarization equator and the circular polarization poles.

Rotator Assembly: +90°

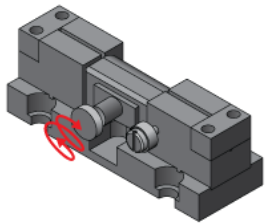
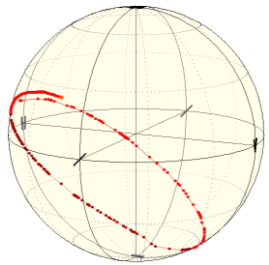

Rotator Assembly: +45°

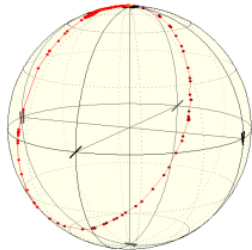

Rotator Assembly: 0°

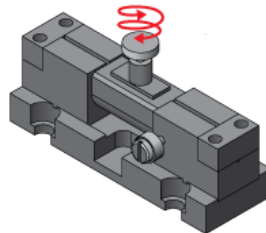
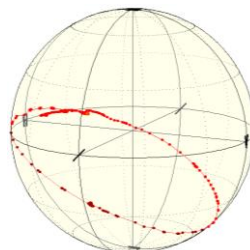

Rotator Assembly: -45°

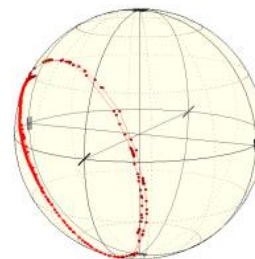

Rotator Assembly: -90°

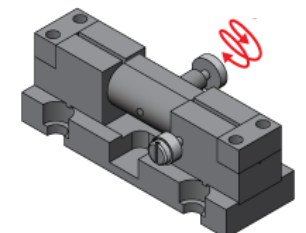
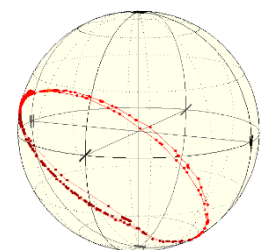

Results: Affect of Rotation Force

- Rotational force on the fiber was visualized by manually rotating the rotator assembly from +90 degrees to -90 degrees with the compression force fixed at approximately 0%, 25%, 50%, 75%, or 100%.
- Applying rotational forces on the fiber rotated the output polarization state about the Poincaré sphere in a similar fashion to rotating a half waveplate.
- It is important to note that the knob can rotate a fair amount (numerous turns) before force will be applied to the fiber. The user will feel resistance once there is force applied to the fiber.

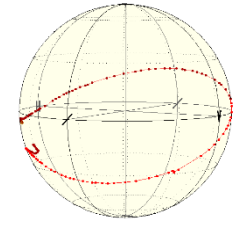
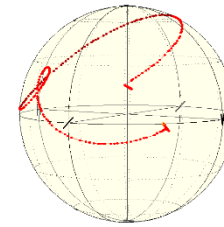
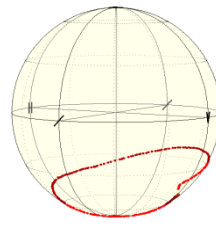
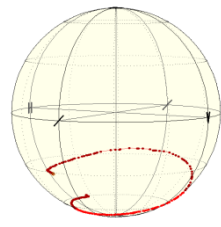
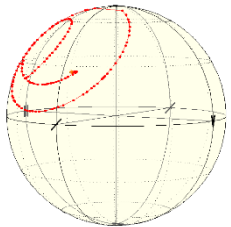
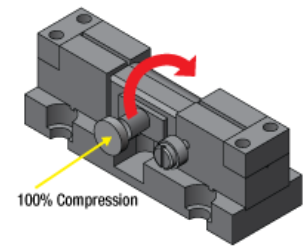
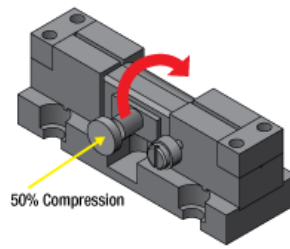
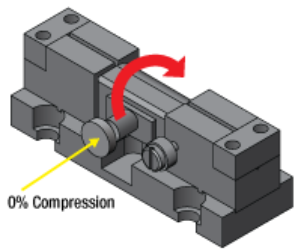

0% Compression

25% Compression

50% Compression

75% Compression

100% Compression

Power Minimization Protocol

- Compression and rotational forces were applied in iterative steps to achieve the desired polarization state.
 - In the example to the right, we started with an arbitrary polarization state (*) and achieved **Horizontal** state ('H').
- Total power from fiber output, P_0 , was recorded with a power meter and then the analyzer was aligned to the orthogonal direction with respect to desired polarization state (**Vertical** in this example). A single force was then applied until a minimum power, P_r , was measured through the analyzer.
 - In this example, the fiber was first squeezed (with rotation locking screw engaged) until the minimum power was measured at the linear polarization state (path 1 in the figure).
- Compression (blue line) and rotational (red line) forces were applied individually in an iterative fashion until the minimum power was measured at each force step.
- The desired polarization state was achieved once an acceptable polarization extinction ratio (P_r / P_0) on order of -30 dB was measured.
 - It is important to note that while the figure above was created from real data, it was created by removing the analyzer from the path and connecting the location of minimum power with the end point of the previous iteration for demonstration purposes. The actual path and number of iterations are dependent on various parameters (see next slide).

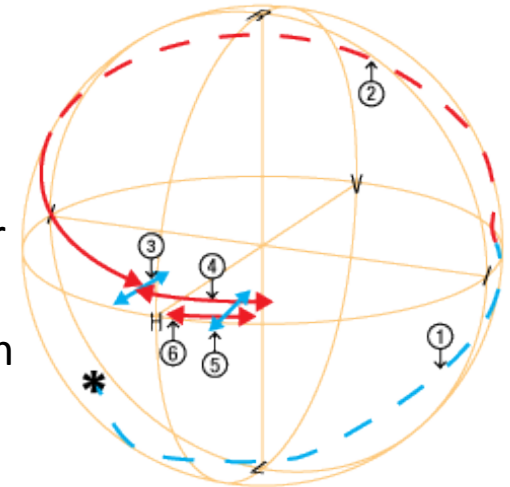

Compression ——— blue line
Rotation ——— red line

Experimental Limitations

- The in-line polarization controller PLC-900 only accepts $\varnothing 900 \mu\text{m}$ tight-buffered fiber, limiting compatibility of this product with other fibers.
- Both compression and rotation forces are prone to mechanical backlash such that a false minimum can appear during a single iteration of the power minimization protocol. It is optimal to iterate a few times or start from the beginning if the desired polarization extinction ratio has not been achieved.
- A hysteresis exists with the rotation force resulting in slightly different paths depending on whether the rotator travels from +90 to -90 degrees or vice versa.
- It is possible to break the fiber if the user applies too much compression to the fiber.
- It is important to note that all measurements were recorded at room temperature with the fiber taped to the optical table. It is possible for environmental effects to the fiber, such as temperature variations and vibration, could change the output polarization state.

Summary

- Measurements were recorded to examine the changes in polarization state for $\varnothing 900 \mu\text{m}$ tight-buffered fiber when using an inline polarization controller (PLC-900).
- Experimental results show the following:
 - Applying compression force on the fiber rotated the output polarization state about a circle on the Poincaré sphere, similar to rotating a quarter-wave plate.
 - Applying rotation forces on the fiber rotated the output polarization state about the Poincaré sphere in a similar fashion to rotating a half-wave plate.
 - Both compression and rotation forces are prone to mechanical backlash with some hysteresis resulting in a false minimum during a single iteration of the power minimization protocol.
- A procedure was created to achieve a free-space polarization state after the polarization controller using an analyzer aligned to the orthogonal state and a polarization extinction ratio of 1,000:1 (-30 dB).