

PY004Z8 - October 4, 2023

Item # PY004Z8 was discontinued on October 4, 2023. For informational purposes, this is a copy of the website content at that time and is valid only for the stated product.

MOTORIZED PITCH AND YAW PLATFORM

- ▶ **Low Profile: 25 mm (0.98") Platform Height**
- ▶ **±2.5° Pitch and ±4.0° Yaw**
- ▶ **Load Capacity: 2.0 kg (4.40 lbs)**
- ▶ **DC Servo Actuators**



PY004Z8
High-Load Pitch and Yaw Stage with DC Servo Actuators



Application Idea
3-Axis Flexure Stage Mounted Directly to a PY004Z8 High-Load Pitch and Yaw Stage for High-Precision 5-Axis Control

OVERVIEW

Features

- Motorized Pitch and Yaw Adjustment via Included DC Servo Actuators
- 1/4"-20 (M6) Tapped Holes with 1.00" (25.0 mm) Spacing
- Add Rotational Degrees of Freedom to Linear Stages
- 25.0 mm (0.98") Deck Height
- Black-Anodized Aluminum Construction



K-Cube™ DC Servo Motor Controller (Two Required)

This Motorized Pitch and Yaw Platform provides ±2.5° of adjustment in pitch and ±4.0° in yaw. It is designed for use with loads up to 2.0 kg (4.40 lbs), such as lasers, cameras, and 3-axis stages. The actual maximum load will depend on the positioning of the load on the platform (see the table to the right or the Specs tab for more details). The 112.0 mm x 115.0 mm (4.41" x 4.53") top platform is equipped with an array of 1/4"-20 (M6) threaded mounting holes on 1" (25 mm) centers.

The base of the pitch and yaw platform is provided with eight through holes for attachment to metric or imperial optical tables and breadboards. The

Key Specifications^a

Adjustment Range	Pitch: ±2.5° Yaw: ±4.0°	
Minimum Achievable Incremental Movement	Pitch: 7.13 arcsec Yaw: 15.71 arcsec	
Bidirectional Repeatability	Pitch: 27.85 arcsec Yaw: 4.75 arcsec	
Crosstalk	<0.05° (180 arcsec)	
Maximum Horizontal Load Capacity^b	2.0 kg (4.40 lbs)	
Maximum Vertical Load Capacity^c	Load Distance from Top Platform	Max Load
	30 mm (1.18")	1.8 kg (4.0 lbs)
	50 mm (1.97")	1.1 kg (2.4 lbs)
	80 mm (3.15")	0.7 kg (1.5 lbs)
Deck Height	25 mm (0.98")	
Bushing Diameter	9.5 mm (3/8")	
Included Drives	Z812B DC Servo Motors (Qty. 2)	

through holes allow the tapped holes on the unit to be in line with the optical table hole pattern or midway off the optical table hole pattern. The unit can also be secured at any arbitrary position by using two CL6 table clamps (sold separately).

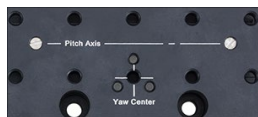

Engravings on the platform indicate the pitch axis and yaw center to help minimize crosstalk.

Included and Compatible Actuators

The two included Z812B DC servo actuators feature a 0.5 m (1.6') cable length. They provide a minimum achievable incremental movement of 7.13 arcseconds in pitch and 15.71 arcseconds in yaw. The

actuators attach to the stage using a flexure clamp that tightens around the $\varnothing 9.5$ mm ($\varnothing 3/8$ ") barrel. If desired, the Z812B

actuator can be replaced by any manual or motorized 13 mm (0.47") actuator that includes a $\varnothing 9.5$ mm ($\varnothing 3/8$ ") barrel, including stepper motor actuators and manual micrometers.

Controller Options

Thorlabs recommends using two KDC101 T-Cube™ Motor Controllers, available below. Each KDC101 provides control for a single axis, with or without a PC. It is compatible with Thorlabs' APT™ software, which supplies out-of-the-box stage control from a PC and enables support for common programming interfaces like LabVIEW, LabWindows, and ActiveX. A USB cable is included with each KDC101. For more information or to download our APT™ software, please see the [APT Software](#) and [APT Tutorials](#) tabs.

- Please see the *Specs* tab for a complete specifications list.
- The load capacity when the stage's base is mounted on a horizontal surface. The max load capacity is different at certain points of the platform. Please click here for more information.
- The load capacity when the stage's base is mounted on a vertical surface. This load capacity will depend on the stage's orientation, the positioning of the load on the top platform, and the distance of the load from the platform. The load data provided is approximate and meant as a guide only.

S P E C S

PY004Z8(/M) Specifications

Specification	Value	
Pitch and Yaw Adjustment		
Adjustment Range	Pitch: $\pm 2.5^\circ$ Yaw: $\pm 4.0^\circ$	
Minimum Achievable Incremental Movement	Pitch: 7.13 arcsec Yaw: 15.71 arcsec	
Bidirectional Repeatability	Pitch: 27.85 arcsec Yaw: 4.75 arcsec	
Maximum Velocity	Pitch: 1781 arcsec/s Yaw: 3142 arcsec/s	
Maximum Acceleration	Pitch: 1781 arcsec/s ² Yaw: 3142 arcsec/s ²	
Crosstalk	<0.05° (180 arcsec)	
Stage		
Maximum Horizontal Load Capacity ^a	2.0 kg (4.40 lbs)	
Maximum Vertical Load Capacity ^b	Load Distance from Top Platform	Max Load
	30 mm (1.18")	1.8 kg (4.0 lbs)
	50 mm (1.97")	1.1 kg (2.4 lbs)
	80 mm (3.15")	0.7 kg (1.5 lbs)
Deck Height	25 mm (0.98")	
Bushing Diameter	9.5 mm (3/8")	
Body Construction	Black-Anodized Aluminum	
Actuator		
Included Drive	Z812B	
Motor Type	DC Servo Motor	

Backlash	<8 μm
Phase to Phase Resistance	33.0 Ω (Max)
Phase to Phase Inductance	0.6 mH (Max)
Calculated Minimum Achievable Incremental Movement	0.05 μm
Operating Temperature Range	41 to 104 $^{\circ}\text{F}$ (5 to 40 $^{\circ}\text{C}$)
Cable Length	0.5 m (1.6')
Connector	D-Type Male
Compatible Controller	KDC101
Physical	
Dimensions (L x W x H) ^c	9.10" x 4.53" x 0.98" (231.0 mm x 115.0 mm x 25.0 mm)
Weight	0.87 kg (1.92 lbs)

- a. The load capacity when the stage's base is mounted on a horizontal surface. The max load capacity is different at certain points of the platform. See the diagram to the right for details.
- b. The load capacity when the stage's base is mounted on a vertical surface. This load capacity will depend on the stage's orientation, the positioning of the load on the top platform, and the distance of the load from the platform. The load data provided is approximate and meant as a guide only.
- c. Including Actuators

How to Calculate the Linear Displacement per Encoder Count

For the Z812B, there are 512 encoder counts per revolution of the motor. The output shaft of the motor goes into a 67:1 planetary gear head. This requires the motor to rotate 67 times to rotate the 1.0 mm pitch lead screw one revolution. The end result is the lead screw advances by 1.0 mm.

The linear displacement of the actuator per encoder count is given by

$$512 \times 67 = 34,304 \text{ encoder counts per revolution of the lead screw,}$$

whereas the linear displacement of the lead screw per encoder count is given by

$$1.0 \text{ mm} / 34,304 \text{ counts} = 2.9 \times 10^{-5} \text{ mm (29 nm).}$$

Horizontal Load Capacity Diagram

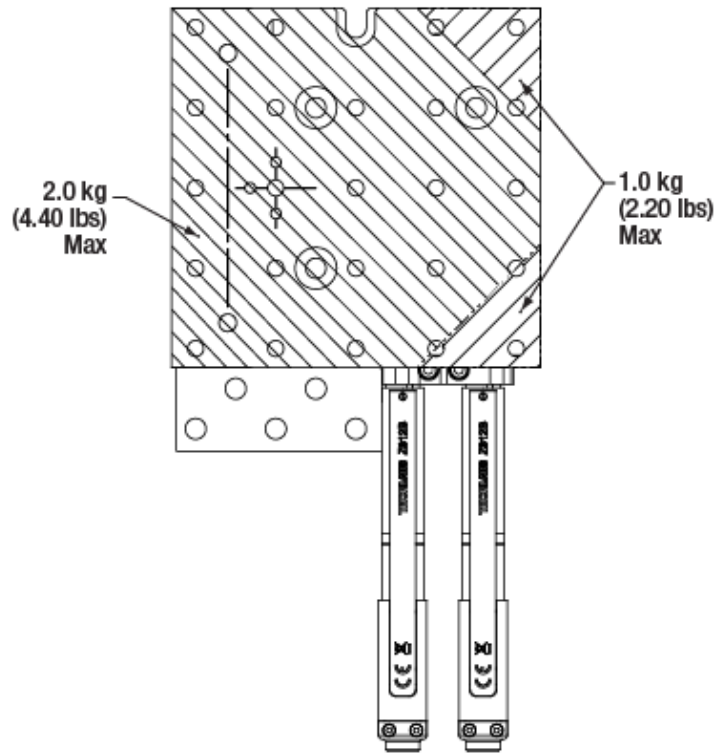

Diagram showing the two areas where the maximum load capacity will change on the PY004Z8(/M)

PIN DIAGRAM

Z812B Connector Pin Out D-Type Male



Pin	Description	Pin	Description
1	Ground (Limit and V_{cc})	8	Reserved for Future Use
2	Forward Limit	9	Ident Resistor
3	Reverse Limit	10	V_{cc} (5 V DC)
4	Reserved For Future Use	11	Encoder Channel A
5	Motor (-)	12	Reserved for Future Use
6	Reserved For Future Use	13	Encoder Channel B
7	Motor (+)	14, 15	Reserved for Future Use

APT SOFTWARE

The APT™ (Advanced Positioning Technology) family covers a wide range of motion controllers ranging from small, low-powered, single-channel drivers (such as the T-Cubes) to high-power, multi-channel, modular 19" rack nanopositioning systems (the APT Rack System).

All controllers in the APT family share a common software platform, the 'APT System Software', which is available on our APT software download page. A support package, containing a wealth of information on using and programming these Thorlabs products is also available.

By providing this common software platform, Thorlabs has ensured that users can easily mix and match any of the APT controllers in a single application, while only having to learn a single set of software tools. In this way, it is perfectly feasible to combine any of the controllers from the low-powered, single-axis to the high-powered, multi-axis systems and control all from a single, PC-based unified software interface.

The APT System Software allows two methods of usage: graphical user interface (GUI) utilities for direct interaction and control of the controllers 'out of the box', and a set of programming interfaces that allow custom-integrated positioning and alignment solutions to be easily programmed in the development language of choice.

A range of video tutorials are available to help explain our APT system software. These tutorials provide an overview of the software and the APT Config utility. Additionally, a tutorial video is available to explain how to select simulator mode within the software, which allows the user to experiment with the software without a controller connected. Please select the *APT Tutorials* tab above to view these videos, which are also available on the software cd included with the controllers.

Software

APT Version 3.21.6

Includes a GUI for control of Thorlabs' APT™ system controllers, as well as a wealth of support information in the form of handbooks, help files, tutorial videos, and FAQs.

Also Available:

- Communications Protocol



APT GUI Screen



APT TUTORIALS

The APT video tutorials available here fall into two main groups - one group covers using the supplied APT utilities and the second group covers programming the APT System using a selection of different programming environments.

Disclaimer: The videos below were originally produced in Adobe Flash. Following the discontinuation of Flash after 2020, these tutorials were re-recorded for future use. The Flash Player controls still appear in the bottom of each video, but they are not functional.

Every APT controller is supplied with the utilities APTUser and APTConfig. APTUser provides a quick and easy way of interacting with the APT control hardware using intuitive graphical control panels. APTConfig is an 'off-line' utility that allows various system wide settings to be made such as pre-selecting mechanical stage types and associating them with specific motion controllers.

APT User Utility

The first video below gives an overview of using the APTUser Utility. The OptoDriver single channel controller products can be operated via their front panel controls in the absence of a control PC. The stored settings relating to the operation of these front panel controls can be changed using the APTUser utility. The second video illustrates this process.

[APT User - Overview](#) [APT User - OptoDriver Settings](#)

APT Config Utility

There are various APT system-wide settings that can be made using the APT Config utility, including setting up a simulated hardware configuration and associating mechanical stages with specific motor drive channels. The first video presents a brief overview of the APT Config application. More details on creating a simulated hardware configuration and making stage associations are present in the next two videos.

APT Programming

The APT Software System is implemented as a collection of ActiveX Controls. ActiveX Controls are language-independent software modules that provide both a graphical user interface and a programming interface. There is an ActiveX Control type for each type of hardware unit, e.g. a Motor ActiveX Control covers operation with any type of APT motor controller (DC or stepper). Many Windows software development environments and languages directly support ActiveX Controls, and, once such a Control is embedded into a custom application, all of the functionality it contains is immediately available to the application for automated operation. The videos below illustrate the basics of using the APT ActiveX Controls with LabVIEW, Visual Basic, and Visual C++. Note that many other languages support ActiveX including LabWindows CVI, C++ Builder, VB.NET, C#.NET, Office VBA, Matlab, HPVee etc. Although these environments are not covered specifically by the tutorial videos, many of the ideas shown will still be relevant to using these other languages.

Visual Basic

Part 1 illustrates how to get an APT ActiveX Control running within Visual Basic, and Part 2 goes on to show how to program a custom positioning sequence.

[APT Programming Using Visual Basic - Part 1](#) [APT Programming Using Visual Basic - Part 2](#)

LabVIEW

Full Active support is provided by LabVIEW and the series of tutorial videos below illustrate the basic building blocks in creating a custom APT motion control sequence. We start by showing how to call up the Thorlabs-supplied online help during software development. Part 2 illustrates how to create an APT ActiveX Control. ActiveX Controls provide both Methods (i.e. Functions) and Properties (i.e. Value Settings). Parts 3 and 4 show how to create and wire up both the methods and properties exposed by an ActiveX Control. Finally, in Part 5, we pull everything together and show a completed LabVIEW example program that demonstrates a custom move sequence.

[APT Programming Using LabVIEW - Part 1: Accessing Online Help](#) [APT Programming Using LabVIEW - Part 2: Creating an ActiveX Control](#) [APT Programming Using LabVIEW - Part 3: Create an ActiveX Method](#)

[APT Programming Using LabVIEW - Part 4: Create an ActiveX Property](#) [APT Programming Using LabVIEW - Part 5: How to Start an ActiveX Control](#)

The following tutorial videos illustrate alternative ways of creating Method and Property nodes:

[APT Programming Using LabVIEW - Create an ActiveX Method \(Alternative\)](#) [APT Programming Using LabVIEW - Create an ActiveX Property \(Alternative\)](#)

Visual C++

Part 1 illustrates how to get an APT ActiveX Control running within Visual C++, and Part 2 goes on to show how to program a custom positioning sequence.

[APT Programming with Visual C++ - Part 1](#) [APT Programming with Visual C++ - Part 2](#)

MATLAB

For assistance when using MATLAB and ActiveX controls with the Thorlabs APT positioners, [click here](#).

To further assist programmers, a guide to programming the APT software in LabVIEW is also available [here](#).

Motorized Pitch and Yaw Platform



- DC Servo Actuator Provides a Large Adjustment Range:
 - Pitch: $\pm 2.5^\circ$
 - Yaw: $\pm 4.0^\circ$
- Maximum Load Capacity: 2.0 kg (4.40 lbs)
- Controllers and Power Supplies Sold Separately

Thorlabs' PY004Z8(/M) Motorized Pitch and Yaw Stage provides an adjustment range of $\pm 2.5^\circ$ and $\pm 4.0^\circ$ in pitch and yaw,

respectively. An array of 1/4"-20 (M6) tapped holes allows easy integration with a wide variety of common optomechanical setups. The stage features a load capacity of 2.0 kg (4.40 lbs), making it ideal for use with lasers, cameras, or 3-axis platforms. The stage requires two controller units and power supplies to operate. For this purpose, we recommend our KDC101 Kinesis® DC Servo Motor Controllers and KPS201 Power Supplies, which are described in more detail below.

Part Number	Description	Price	Availability
PY004Z8/M	Motorized Pitch and Yaw Platform, DC Servo Motors, M6 Taps	\$2,413.11	Lead Time
PY004Z8	Motorized Pitch and Yaw Platform, DC Servo Motors, 1/4"-20 Taps	\$2,413.11	Lead Time

K-Cube™ DC Servo Motor Controller



- Front Panel Velocity Wheel and Digital Display for Controlling Motorized Stages or Actuators
- Two Bidirectional Trigger Ports to Read or Control External Equipment
- Interfaces with Computer Using Included USB Cable
- Fully Compatible with Kinesis® or APT™ Software Packages
- Compact Footprint: 60.0 mm x 60.0 mm x 49.2 mm (2.42" x 2.42" x 1.94")
- Power Supply Not Included (See Below)



KCH601 USB Controller Hub (Sold Separately) with Installed K-Cube and T-Cube™ Modules (T-Cubes Require the KAP101 Adapter)

Thorlabs' KDC101 K-Cube Brushed DC Motor Controller provides local and computerized control of a single motor axis. It features a top-mounted control panel with a velocity wheel that supports four-speed bidirectional control with forward and reverse jogging as well as position presets. A backlit digital display is also included that can have the backlit dimmed or turned off using the top-panel menu options. The front of the unit contains two bidirectional trigger ports that can be used to read a 5 V external logic signal or output a 5 V logic signal to control external equipment. Each port can be independently configured.

The unit is fully compatible with our new Kinesis software package and our legacy APT control software. Please see the *Motion Control Software* tab for more information.

Please note that this controller does not ship with a power supply. Compatible power supplies are listed below. Additional information can be found on the main KDC101 DC Servo Motor Controller page.

Part Number	Description	Price	Availability
KDC101	K-Cube Brushed DC Servo Motor Controller (Power Supply Not Included)	\$757.51	Today

Compatible Power Supplies



- Individual Power Supply
 - KPS201: For K-Cubes™ or T-Cubes™ with 3.5 mm Jacks
- USB Controller Hubs Provide Power and Communications
 - KCH301: For up to Three K-Cubes or T-Cubes
 - KCH601: For up to Six K-Cubes or T-Cubes

The KPS201 power supply outputs +15 VDC at up to 2.66 A and can power a single K-Cube or T-Cube with a 3.5 mm jack. It plugs into a standard wall outlet.



The KPS201 Power Supply Unit



Each KPS201 power supply includes one region-specific adapter, which can be selected upon checkout.

The KCH301 and KCH601 USB Controller Hubs each consist of two parts: the hub, which can support up to three (KCH301) or six (KCH601) K-Cubes or T-Cubes, and a power supply that plugs into a standard wall outlet. The hub draws a maximum current of 10 A; please verify that the cubes being used do not require a total current of more than 10 A. In addition, the hub provides USB connectivity to any docked K-Cube or T-Cube through a single USB connection.

For more information on the USB Controller Hubs, see the full web presentation.

Part Number	Description	Price	Availability
-------------	-------------	-------	--------------

KPS201	15 V, 2.66 A Power Supply Unit with 3.5 mm Jack Connector for One K- or T-Cube	\$39.54	Today
KCH301	USB Controller Hub and Power Supply for Three K-Cubes or T-Cubes	\$586.89	Today
KCH601	USB Controller Hub and Power Supply for Six K-Cubes or T-Cubes	\$710.31	Today

Motor Extension Cable



The PAA632 Extension Cable provides an additional 2.5 m (8.20 ft) of cable length for the 15-pin D-type connectors used throughout our motorized actuator selection. The male end connects to the controller, while the female end connects to the motor.

Part Number	Description	Price	Availability
PAA632	APT DC Servo Motor Cable for Z8 Motors, DE15 Male to DE15 Female, 2.5 m	\$64.64	Today