

# 1" Travel Translation Stage

The PT Series of translation stages features hardened steel linear bearings for precise motion and long life over the full 1" travel range. The modular design allows for quick XZ or XYZ configuration as the application requirements develop. This quick-change design is achieved using precision-aligned dowel pins to ensure orthogonality between stages.

These stages are also easily reconfigured from right-handed to left-handed use. They can be purchased individually (PT1) or as preconfigured 3-axis XYZ translators (PT3). The 3/8" (PT1) or 9.7 mm (PT1/M) mounting barrel allows for a wide range of manual and motorized actuators to be interchanged effortlessly with a single screw. See page 445 for details on the PT1-Z8 motorized option. Two- and three-axis stages can be made from any combination of manual and motorized stages.

## Features

- Easily Configured in XZ and XYZ Orientations
- Wide Range of Compatible Actuators and Adjusters
- 1/4"-20 (M6 x 1.0) Mounting Holes
- Lockable Coarse Adjustment (PT1A Only)
- Left- or Right-Hand Configurable

## Micrometer Drive

- Adjustment Range: 1.0"
- Graduation (per Division): 0.001" (10 µm)

## Differential Drive

- Course Adjustment Range: 1.0"
- Fine Adjustment Range: 250 µm
- Fine Adjustment Graduation (per Division): 0.5 µm

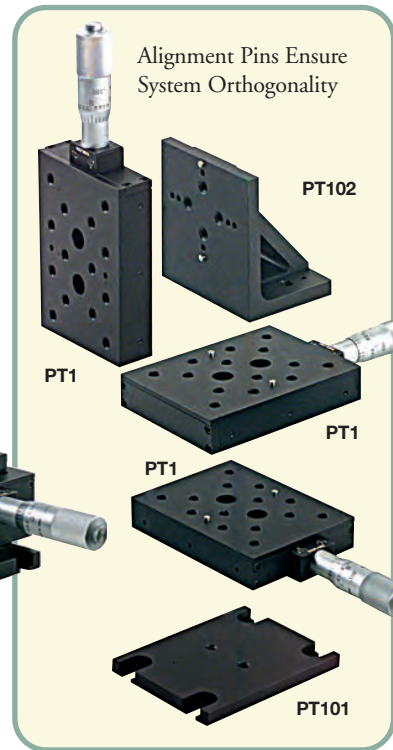

Manual Stages      See Our Motorized Stages Chapter for Details on these Specialized Products      Motorized Stages

See Page 445

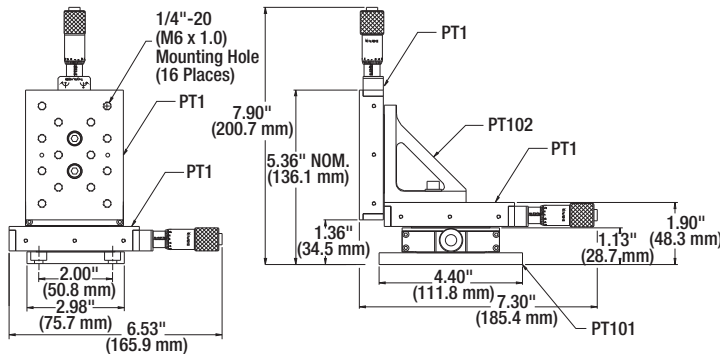
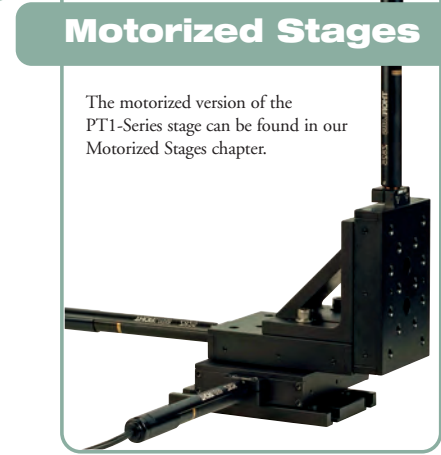

## Specifications

- Travel Range: 1"
- Vertical Load (Max): 20 lbs (9 kg)
- Horizontal Load (Max): 90 lbs (41 kg)
- Orthogonality: <5 mrad
- Angular Deviation: <250 µrad
- Bearing Type: Ball on Hardened V-Grooves



## Single-Axis Translator Plus Accessories

ITEM#	METRIC ITEM#	\$	£	€	RMB	DESCRIPTION
PT1	PT1/M*	\$ 259.00	£ 179.60	€ 230.00	¥ 2,187.10	1" Travel Translation Stage, Micrometer Drive
PT101	PT101	\$ 15.60	£ 10.80	€ 13.90	¥ 131.80	Base Plate for PT Series
PT102	PT102/M	\$ 68.60	£ 47.60	€ 61.00	¥ 579.30	Angle Bracket for PT Series
PT1A	PT1A/M	\$ 357.80	£ 248.10	€ 317.70	¥ 3,021.30	1" Travel Translator Stage, Differential Adjuster

\*All prices include micrometers as noted in the description box.

## XYZ Stages

ITEM#	METRIC ITEM#	\$	£	€	RMB	DESCRIPTION
PT3	PT3/M*	\$ 829.90	£ 575.40	€ 736.80	¥ 7,007.70	XYZ 1" Travel Translation Stage, Micrometer Drive
PT3A	PT3A/M*	\$1,038.00	£ 719.60	€ 921.60	¥ 8,764.90	XYZ 1" Travel Translation Stage, Differential Adjuster

\*All prices include micrometers as noted in the description box.