

Ø1.5" Cylindrical Laser Mount

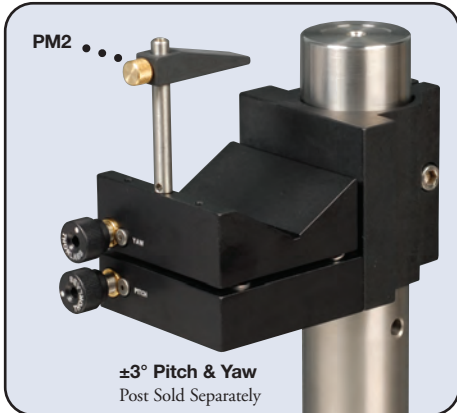

- ±3° Pitch and Yaw Adjustment for Easy Beam Steering
- Kinematic Design Provides Stability
- Ø2.00" (Ø50.8 mm) Maximum and Ø0.56" (Ø14.2 mm) Minimum Clamping Diameter
- Compatible with Standard Ø1.5" Mounting Posts

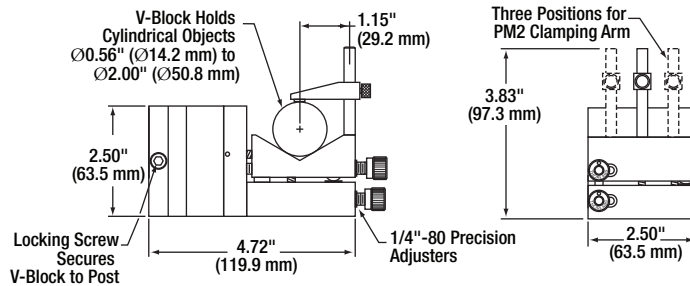
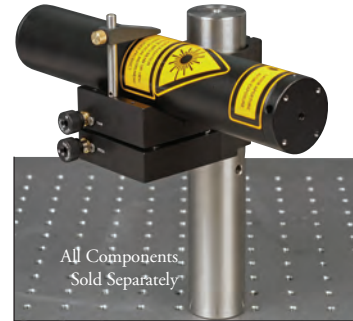

Please refer to our website for complete models and drawings.

ITEM#	METRIC ITEM#	\$	£	€	RMB	DESCRIPTION
C1503*	C1503/M*	\$ 221.00	£ 153.30	€ 196,30	¥ 1,866.20	Kinematic V-Clamp Mount
PM2	PM2/M	\$ 14.70	£ 10.20	€ 13,10	¥ 124.20	Large Clamping Arm

*One PM2 or PM2/M included with each unit.

The C1503 is a Kinematic V-Clamp Mount that provides two axes of precision angular adjustment. This clamp is ideal for mounting a HeNe laser or other large cylindrical objects. The angular adjustments provide control of the beam pointing, while the vertical height can be set by moving the unit along the support post (see page 100). Once the desired vertical position is achieved, the clamping mechanism is actuated with a 3/16" (5 mm) hex key or balldriver. True kinematic movement is achieved using a series of hardened steel balls and ball seats in conjunction with heavy-duty springs, all of which provide long-term stability.

Post V-Clamp Mount

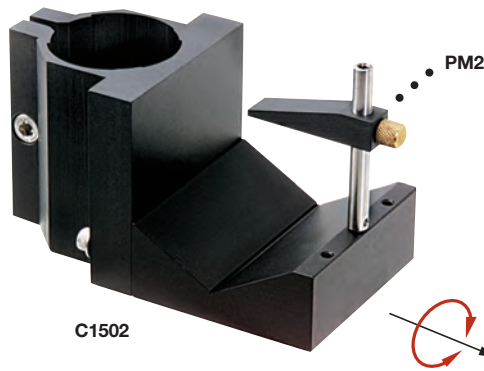

TOOLS OF THE TRADE

Excellent for Holding Our HeNe Lasers

See Pages
1074-1077

17 mW
632.8 nm HeNe

The C1502 will accept cylindrical objects ranging in diameters from Ø0.56" (Ø14.2 mm) to Ø2.00" (Ø50.8 mm). Each unit comes with one clamping arm (PM2); extra arms can be purchased separately (see below). The V-clamp can be manually adjusted within a ±10° range and then locked in place with two #8-32 (M4 x 0.7) socket head cap screws. Vertical positioning is achieved by sliding the rear clamping mechanism along the length of the Ø1.5" post. Once the desired vertical position is achieved, the clamping mechanism is actuated with a 3/16" (5 mm) Allen key or balldriver.

ITEM#	METRIC ITEM#	\$	£	€	RMB	DESCRIPTION
C1502*	C1502/M*	\$ 92.00	£ 63.80	€ 81,70	¥ 776.90	Post V-Clamp Mount
PM2	PM2/M	\$ 14.70	£ 10.20	€ 13,10	¥ 124.20	Large Clamping Arm

*One PM2 or PM2/M included with each unit.

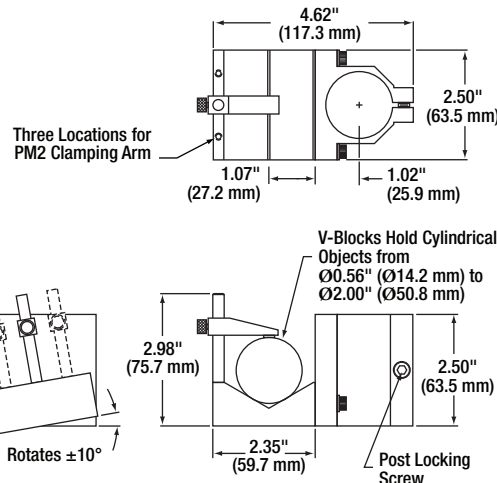

Please refer to our website for complete models and drawings.